

TECHNICAL SERVICE
+39 0522 869832

CENTRIFUGAL PUMPS

CN Series



**INSTRUCTIONS FOR INSTALLATION,
OPERATION AND MAINTENANCE**

INDEX

	FOREWORD
1	SYMBOLS
2	SAFETY WARNINGS
3	GUARANTEE
4	GOODS TRANSPORTATION, RECEIVING AND TRANSFERRING
	4.1 Transportation
	4.2 Receiving
	4.3 Transferring
5	DESCRIPTION
	5.1 Sound pressure level
6	NON-PERMITTED USES
7	INSTALLATION
	7.1 Suction and inflow conditions
	7.2 Piping
	7.3 Electrical connection
8	OPERATION
	8.1 Preliminary operations
	8.2 Starting
	8.3 Operating checks
9	SEALS
	9.1 Mechanical seals
10	SPARE PARTS
11	WORKING IRREGULARITIES
12	DISASSEMBLY OF CN PUMP "T" EXEC.
13	ASSEMBLY
14	EXTENDED STOP
15	CLEANING PROCEDURE (CIP –CLEANING IN PLACE)
16	DECOMMISSIONING

Version: 07

Date: 20/11/18

INTRODUCTION

- This manual contains the instructions for the C.S.F. centrifugal pumps of CN series relative to receiving, delivery, installation and maintenance. The information given here in is of a general nature. Specific information for each version is given in the respective annexes.

C.S.F. INOX SpA reserves the right to amend or modify the content of this manual without prior notice. This instruction manual contains the information necessary to understand and use the centrifugal pumps CN series produced by C.S.F. INOX SpA. We recommend reading this manual and keeping it for future reference in a safe place near the pump itself.



- When requesting information, replacement parts or assistance, always specify the pump type (*) and serial number (**) indicated on the identification plate, or the complete part number given in the purchase documentation.

POMPE - RACCORDERIA
Montecchio E. - ITALY
☎ 0522869911 - <http://www.csf.it>

○ Modello ○

Plate example

1 SYMBOLS

	WARNING	<i>Pay great attention to the text parts indicated by this symbol.</i>
	Danger:	<i>the non-observance of instructions can cause serious damages to persons and/or objects.</i>
	Danger:	<i>only skilled personnel is allowed to carry out operations concerning the electric parts.</i>

2 SAFETY WARNINGS

When the pump is working the following occurs:

- Electric parts are in tension.
- Mechanical parts are moving.
- Pump body, pipelines and articulations are under internal pressure. Therefore do not remove any protection or locking, do not loosen screws or clampings, as this can cause serious damages to persons or objects. The clamp joining the pump casing and the cover must be well tightened and it should not be easily unscrewed by hand.
- Non-observance of inspection and maintenance can cause damages to persons and objects, especially when dangerous or toxic liquids are pumped.
- When pumping liquids at a temperature over 60°C, adequate protection and warning signals are required.

- When you buy a pump with bare shaft, motor coupling operations have to be carried out according to technical directions and law, providing adequate protections for joints, gear belts, etc.

- Operations on the electric parts have to be carried out by skilled personnel, according to technical directions and law, on authorization of the responsible installer.

- Installation must ensure an adequate ventilation, in order to cool the engine, as well as enough space for maintenance operations.

Before carrying out any operation which requires to disassemble the pump (inspection, cleaning, seal replacement, etc.), the following preliminary operations have to be carried out:

- switch off engine tension and disinsert electric connection;
- close valves on suction and outlet pipelines, in order to avoid the risk of inundation;
- use adequate protections for hands and face, if the pump contains liquids which are injurious to health (for example acids, solvents, etc.);
- consider if the liquid which flows out of the pump when disassembling is dangerous and arrange for adequate safety measures.

3 GUARANTEE

All products manufactured by C.S.F. Inox are guaranteed to the purchaser, for one year from the date of purchase, against hidden defects in materials or manufacture, providing that they are installed and used according to instructions and recommendations of the manufacturer. Excluded from the guarantee other than distinctive wear and tear are repairs to damage caused by improper use, abrasion, corrosion, negligence, defect of installation, non-observance of inspection and maintenance, use of non-genuine spare parts, cause of accident or fortuity and from any action carried out by the purchaser not according to the normal instructions of the manufacturer.

WARNING Before returning to C.S.F. Inox S.p.A. any item to be substituted or repaired under guarantee, inform about the problem the Customer Assistance Office and follow instructions of the manufacturer.

Any item must be properly packed in order to avoid damages during the transferring and **a technical report explaining the fault occurred, must accompany the returned item/s.**

Any item with a presumed fault should be returned to C.S.F. Inox S.p.A. with shipment costs at purchaser's charge, unless different agreements are given.

C.S.F. Inox S.p.A. will examine, repair and/or replace the returned piece and then send it back to the purchaser on ex-works basis. Should the piece be found under warranty, no further costs will be debit the purchaser. If, on the contrary, the fault is not found under warranty, all necessary reparations and replacements will be charged at normal cost to the purchaser. Commercial parts incorporated in C.S.F. products are guaranteed by their corresponding manufacturers.

4 GOODS TRANSPORTATION, RECEIVING AND TRANSFERRING

4.1 TRANSPORTATION

The packings of all pumps manufactured by C.S.F. Inox S.p.A. are defined when placing the order. Unless prior arrangements are given, goods will be packed only for transit conditions and not for long-term storage; in case it should be necessary to store the pumps outside, you are requested to cover the pumps appropriately in order to protect the electrical parts (motor) from rain, dust, humidity etc.

4.2 RECEIVING

WARNING By goods receiving, the wholeness of packing must be verified, in order to identify possible damages to the content occurred during transferring and to claim them immediately to the carrier. Should any damage be ascertained, the following procedure must be observed:

- collect the goods with reservation;
- take the necessary pictures showing the damages;
- notify the suffered damages, by registered airmail, to the carrier by sending at the same time the pictures taken to show the damaged pieces.

4.3 TRANSFERRING

Carry the packed pumps as close as possible to the place of installation by means of appropriate lifting devices and unpack them. During this operation take care, as unsteady parts could fall down.

The material used for packing (wood, paper, cellophane, etc.) should be properly got rid, according to the corresponding rules in force in receiver's country.

After unpacking the pump, use special lifting belts and move the pump-motor-set to the place of installation; never use the eyebolts on the motor to move the pump, as the eyebolts are for moving the motor only. In versions complete with shroud, take the shroud off before moving the pump-motor-set, in order to avoid damages.

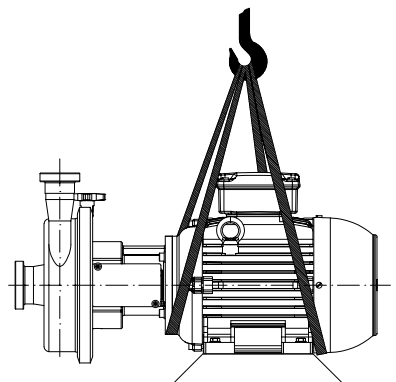

5 DESCRIPTION

The CN series pumps are single-stage centrifugal pumps with axial suction port, open centrifugal impeller with reversed blades and independent shaft.

All models have threaded connections for fittings to DIN 11851 standards (unless otherwise requested) and are fitted with unified mechanical seals according to EN 12756 - ISO 3069 standards, material are chosen according to the liquid to be pumped. The clamp casing and seal design allows quick disassembly for inspection, cleaning and maintenance.

They are intended for professional use.

These pumps are designed for applications where the liquid to be pumped :

- is not subject to pollution of any kind,
- is at a temperature between $-10^{\circ}\text{C} \div 120^{\circ}\text{C}$
- is chemically aggressive

They are fitted with three-phase electric motors with IP 55 protection rating.

5.1 SOUND PRESSURE LEVEL

The sound pressure level of centrifugal pumps is the following (see table):

The measurement has been made by means of a phon-meter placed at 1 m distance from the pump and at a height of 1.6 m from the ground.

Preliminary condition is that the pump is fixed correctly; the above mentioned values do not take into account external noise sources (e.g. valves, abrupt hydraulic deflections).

Sound pressure level dB(A)	Pump type	
	75 ÷ 80	CN 1
80 ÷ 85	CN 2	2 poles
85 ÷ 88	CN 3	2 poles
< 70	CN 1	4 poles
	CN 2	4 poles
	CN 3	4 poles

6 NON-PERMITTED USES

Do not use the pump with a suction pressure greater than the specified value (0.5 times the discharge head generated by the pump).

The pump must always be used in an environment appropriate to the level of protection of the motor. Always check this on the motor plate before installation.

WARNING THE PUMP MAY NOT BE USED IN ENVIRONMENTS WHICH REQUIRE A HIGHER LEVEL OF PROTECTION OR A HIGHER SPECIFICATION MOTOR OR ELECTRICAL PARTS.

Components complying with the safety standards for the environment in question must be used.

7 INSTALLATION

7.1 SUCTION AND INFLOW CONDITIONS

(NPSH = Net Positive Suction Head)

NPSH of system (available NPSH)

In order to ensure that pump operation is free from cavitation, it is essential to observe the maximum permitted suction lift **ha geo max** or the minimum allowable head **hc geo min**.

NPSH of pump (required NPSH)

The centrifugal pumps can operate correctly only if vapour has not formed inside. For this reason the static head at the reference point for the NPSH is the centre of the impeller, that is the point of intersection of the pump shaft axis with the vertical plane that passes through the external points of the blade inlet corners.

NPSH is the value required by the pump, expressed in metres, obtained from the performance curve. In practice 0.5 m should be added to this value as a safety margin.

7.2 PIPING

In order to prevent the creation of harmful stresses, the suction and discharge pipes must be connected to the pump ports without the use of force. These pipes must also be supported independently avoiding causing stresses on the pump. The internal diameter must be the same size as the pump connections. It must in any case not be smaller to avoid head loss and/or poor performances.

Always use elbows with large radius. If the pipe diameter changes along the line, use reduction cones, choosing the ones that are most suitable to avoid any formation of air pockets (Pict.1).

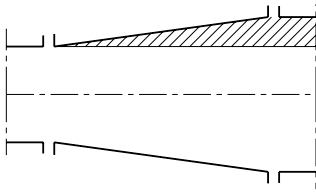

NO

Pict. 1

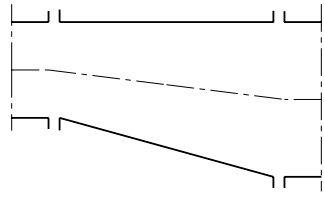

YES

The suction pipe must be as short as possible and rise as it moves towards the pump if it is sucking from a tank (Pict.2). Always fit a bottom valve with a suction rose. If on the other hand the pump is below the level of the liquid, the pipe should descend slightly (Pict.3). If the pump is used for transporting hot liquids, fit expansion joints to compensate any expansion of the piping. The maximum velocity of the liquid in the suction pipe must not be greater than 3 m/s. Velocities between 1 and 2 m/s are recommended. The suction pipe must be designed in such a way as to prevent air from entering the pump.

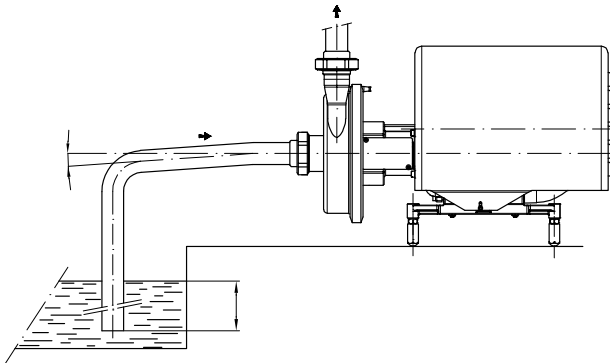

Pict. 2

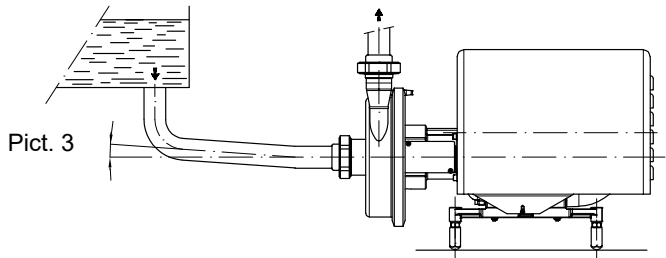

Pict. 3

For this reason, when sucking from a tank located at a lower level, the pipe must reach below the free surface of the liquid. In order to prevent the formation of vortices and avoid the risk of sucking in air, always keep a minimum head at the pipe inlet (h_{min}) equal to at least the dynamic head plus a safety margin of 0.1 m (Pict.2).

$$h_{min} = \frac{V^2}{2g} + 0,1$$

$$h_{min} = m$$

$$V = m/s$$

In order to prevent the formation of vortices when it is not possible to observe the values of minimum available head, it is possible to fit crosses in the piping. This system is suitable even for tanks with a positive head.

- Avoid creating obstacles which could increase suction losses disrupting smooth fluid flow. Make sure that there are no restrictions, sharp turns or tight elbows on the discharge line, since these increase disturbance.

7.3 ELECTRICAL CONNECTION



Make the electrical connection only after the hydraulic connection has been completed; set up the motor control system in conformity with the technical standards and regulations in force (EN 60204-1): in particular a manual electric power switch must be installed with adequate current switching capacity; devices for overcurrent and overload protection (e.g. fuses, automatic switches, etc.) must also be fitted, plus, if necessary, a device to prevent accidental restarting.

Check that the main frequency and voltage and the available power are suitable for the motor installed. All the material used for the electrical connection (cables, cable clamps, switches and shielding) must have a suitable level of protection for the environment in which it is installed. Be sure to use cables of sufficient cross-section for the current shown on the motor plate so as to prevent them from overheating.

Before doing anything else, make the motor's earth connection, using the terminal on the motor and a cable of sufficient cross-section. The cables may be connected to the terminal board using either a delta or star arrangement. Follow the data given on the motor plate for the main voltage, as shown in the diagram in pict.4; ensure that the terminals are clean and tight and not under stress.

When starting, the motor's current absorption increases briefly to 5-6 times the nominal value. If the mains supply is unable to sustain this increase in absorption, use a star-delta starter or other kind of device (e.g. an autotransformer).

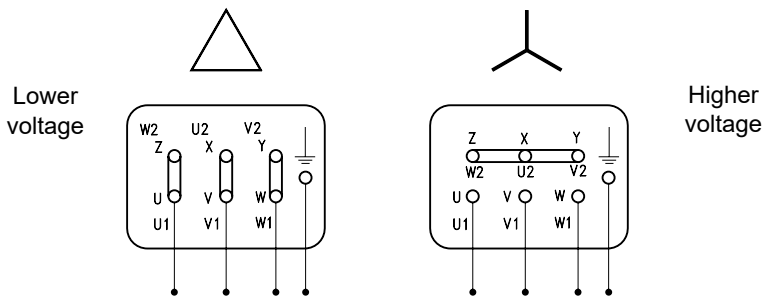

Pict.4

C.S.F. Inox S.p.A. will accept no responsibility for damage to property and/or injury to persons caused by failure to comply with technical standards and regulations in force.

8 OPERATION

8.1 PRELIMINARY OPERATIONS



- Check that the pump turns freely under hand pressure.
- Check that the clamp joining the pump casing and the cover is well tightened and that it cannot be easily unscrewed by hand. The tightening of the clamp must be carried out by means of a key and NOT by hand.
- Check that the pump turns in the marked direction (CLOCKWISE, as seen from the control end).
- The suction pipe and the pump must be filled with liquid. There are two possible cases:
 - a) When the pump is to operate with a negative suction head, it must be primed by introducing liquid into the pump body.
 - b) When the pump is to operate below the level of the suction liquid, i.e. with a positive head, the suction and discharge gate valves must be opened until the pressure gauge on the pump discharge shows a pressure corresponding to the positive suction head.
- If the sealing chamber is to be cooled, open the cooling water supply and adjust the flow.

8.2 STARTING

- Carry out the preliminary operations, then close the discharge gate valve completely and make sure that the suction gate valve is completely open.
- Start the pump and check once again that it rotates in the right direction.

8.3 OPERATING CHECKS

- If the pump does not generate the required discharge head rapidly, stop and repeat the priming operations.
- If the discharge gate valve is opened more than necessary, i.e. further than the specified working point, and the pump is operating with a lower discharge head than that required, there will be an increase in delivered capacity and absorbed power. If this occurs, throttle the discharge until the required head and capacity values are obtained.
- If the discharge head generated by the pump is greater than that required, the diameter of the impeller can be reduced. If, on the other hand, the discharge head is lower than required, with the same capacity, it will be necessary to install a larger diameter impeller (if the one fitted is not already the largest available) and probably also a higher power motor.
- The pump must operate smoothly and without vibrations.
- Do not operate without liquid and in any case avoid prolonged operation with the discharge gate valve closed.
- Check that the suction liquid level is always sufficient to guarantee an adequate energy load for normal operation of the pump.
- Mechanical seal: check that there is no leakage along the shaft.

9 SEALS

The CN centrifugal pumps are fitted with **mechanical seals**. The type of mechanical seal and material are chosen according to the liquid to be pumped.

9.1 MECHANICAL SEALS

A mechanical seal is a device intended to retain fluid and prevent it from escaping from the pump. The seal consists of two sliding surfaces, with one rotating relative to the other, held in axial contact by the pressure generated by the fluid (hydraulic force) and by components such as springs or bellows (mechanical force). Mechanical seals are generally cooled by the fluid itself. The materials used are selected in relation to the characteristics of the fluid used, the operating conditions in which the seal is installed and the performance required.

WARNING Before using the pump with products which are not mentioned in your order, check that the seal type suits the new product to be pumped.

Different types of seal are available with CN centrifugal pumps:

EXEC. "T"

- Internal mechanical seal "T" . . "

The rotary mechanical seal is internally mounted to ensure effective lubrication, cooling and consequently minimised wear. The seal type, face materials and elastomers are chosen from a range of several options, to suit the nature of the product being handled and the specific application requirements.

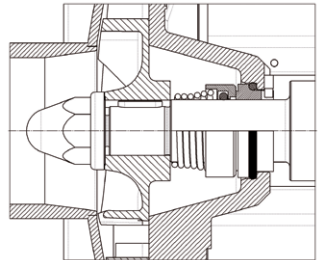

EXEC. "TH."

- Internal mechanical seal "TH" . . "

Protected spring and hydraulically balanced; especially suited for high cleanliness, vacuum and semi-viscous product applications. Easy to clean with CIP, it is perfect for use with foodstuffs, sanitary products, pharmaceuticals and wherever process sterilisation is a requirement.

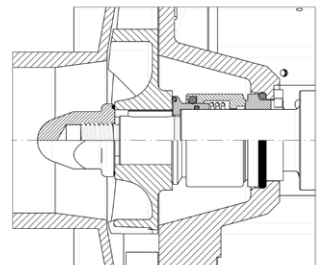

10 SPARE PARTS

RECOMMENDED SPARE PART FOR TWO YEARS OF OPERATION ACCORDING TO THE NUMBER OF PUMPS INSTALLED - VDMA STANDARD					
Denomination	NUMBER OF PUMPS (including reserve)				
	1	2	3	4	5
MECHANICAL SEAL	1	2	3	4	4
PUMP COVER O-RING SEAL	2	3	5	6	7
IMPELLER NUT " O-RING SEAL	2	3	5	6	7

C.S.F. Inox declines all responsibility for damage or injury resulting from the use of non-original spare parts.

11 WORKING IRREGULARITIES

We are herewith listing some of the possible working irregularities which may occur using the pumps, with a table helping to find out the possible causes and how to solve the problem.

Trouble:

- A) The pump does not run
- B) The delivery is not sufficient
- C) The pressure is not sufficient
- D) The pump stops priming
- E) Power absorption too higher
- F) Leakages from the mechanical seal
- G) Short life of the mechanical seal
- H) Failure of the mechanical seal
- I) Anomalous vibrations and/or noise
- L) Short life of bearings

Possible causes and necessary operations to solve them:

- 1) The pump is not properly primed.
 - Repeat the priming.
- 2) Air entering from suction connections.
 - Check the lock.
- 3) Air entering from the mechanical seal.
 - Replace the mechanical seal or arrange a solution with a vacuum spring in case of vacuum suction operation.
- 4) Obstructions present along suction pipes or valves closed along pipes.
 - Verify and remove all foreign matters from pipes and finally verify valves status (if closed, open them).
- 5) NPSH available in the plant is lower than NPSH needed by the pump.
 - Reduce the friction loss or adjust the pump at a lower delivery point.
- 6) Defective operation of the standing valve (not flooded pumps).
 - Restore the proper operation of the valve or replace it with a perfect one.
- 7) Plant friction losses higher than pump performances.
 - Reduce friction losses or replace the pump with a most suitable one for requested performances.
- 8) Opposite direction of rotation or too low velocity (in case of a pump operated by an inverter).
 - Restore the correct sense of rotation; increase the motor speed.
- 9) The impeller is clogged by foreign matters (in case of pump with closed-impeller).
 - Remove foreign matters from the impeller.
- 10) Worn mechanical seals.
 - Replace worn parts.
- 11) Worn or partially clogged impeller.
 - Replace the impeller or remove foreign matters.
- 12) Product viscosity higher than foreseen one.
 - Verify the pump size.
- 13) Presence of too much gas in the fluid.
 - Fit an air relief valve.

- 14) Plant friction losses lower than foreseen ones.
 - Increase friction losses or adjust the pump at a higher working point.
- 15) Fluid specific gravity higher than foreseen one.
 - Increase the installed motor power.
- 16) Pumped fluid too much viscous.
 - Verify the pump size.
- 17) Higher pump delivery during operation due to plant friction losses lower than foreseen ones.
 - Adjust the pump at a lower working point or increase the plant friction losses.
- 18) Rotation speed too high (when pump is controlled by an inverter).
 - Reduce the velocity.
- 19) Internal frictions caused by slipping between rotating and fix parts.
 - Restore normal assembling conditions.
- 20) Misalignment of pump-motor or deformed shaft.
 - Restore the correct alignment between pump and motor; replace the shaft with a new one.
- 21) Damaged bearings of pump or motor.
 - Replace the bearings.
- 22) Electric misconnection.
 - Modify the electric connection by strictly following ratings written on the motor plate according to the available voltage.
- 23) Voltage not suitable for the installed motor.
 - Replace the motor with one having a suitable voltage.
- 24) Mechanical seal too much wear.
 - Replace the mechanical seal.
- 25) Pump fluid or temperature not suitable for the assembled mechanical seal or its parts.
 - Verify the mechanical seal selection.
- 26) Non-cleaning when using fluids which tend to crystallize.
 - Increase washing cycles and don't leave the product laying inside the pump for a long time.
- 27) Misassembly of the mechanical seal.
 - Assemble the mechanical seal again with attention.
- 28) Opposite rotation direction for non-reversible mechanical seals.
 - Restore the correct sense of rotation.
- 29) Flushing non sufficient for external flushed seals.
 - Increase the flushing fluid.
- 30) Dry operation of the pump.
 - Arrange the proper dry-running protection in order to avoid the problem.
- 31) Oscillations on the shaft due to a too high assembly allowance, wear.
 - Restore normal assembly conditions by replacing the wear pieces.
- 32) Suspended solid parts in the fluid.
 - Verify the mechanical seal selection.
- 33) Too high temperature or thermic shock.
 - Increase gradually the fluid temperature by avoiding instantaneous thermic amplitudes; prevent the pump from dry-running.
- 34) Out-of-balance of the impeller.
 - Replace the impeller.
- 35) The pump runs at a low delivery.
 - Adjust the pump at a higher working point.
- 36) The pump runs at a high delivery.
 - Adjust the pump at a lower working point.
- 37) Pump and/or pipes are not properly anchored.
 - Verify and adjust anchorage of the involved parts.
- 38) Bearings not lubricated (where lubrication is foreseen).
 - Replace bearings and restore the proper lubrication of them; lubrication according to the use conditions should be at intervals filled up.
- 39) Water seepage due to wear.
 - Replace wear parts.

		TROUBLE										
		A	B	C	D	E	F	G	H	I	L	M
POSSIBLE CAUSES AND NECESSARY OPERATIONS TO SOLVE THEM	1	●	●									
	2	●	●		●							
	3	●	●		●							
	4	●	●		●							
	5	●	●		●							
	6	●	●									
	7	●	●	●								
	8	●	●	●								
	9	●	●	●		●						
	10		●	●								
	11		●	●						●		
	12		●	●								
	13			●	●							
	14				●							
	15					●						
	16					●						
	17					●						
	18					●						
	19					●				●	●	
	20					●	●	●		●	●	
	21					●				●		
	22		●	●		●						
	23		●	●		●						
	24						●					
	25						●	●	●			
	26						●	●	●			
	27						●	●				
	28						●					
	29						●	●				
	30						●	●				
	31						●	●				
	32							●				
	33								●			
	34									●	●	
	35									●		
	36									●		
	37									●		
	38										●	
	39											●

**12 DISASSEMBLY OF CN PUMP "T" EXEC.
(Version with single mechanical seal)**

Remove the screws (36-38) to disassemble shroud (41).
Disassemble the feet support (128) from motor (50) removing the bolts (110) and the nuts (111).

NB: PLACE THE PUMP UPRIGHT

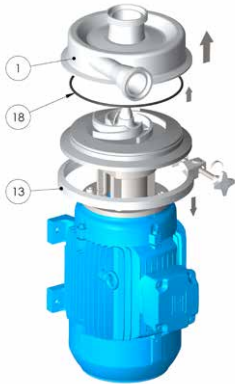
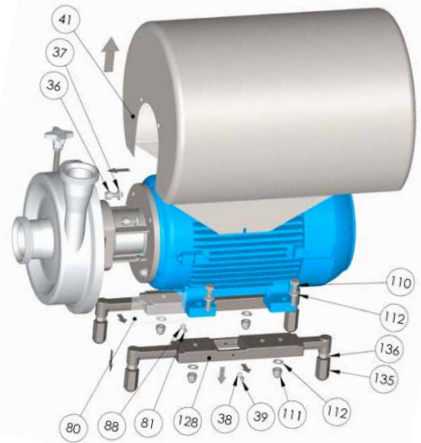

Loosen the clamp (13) to pull out the pump casing (1) and O-ring (18).

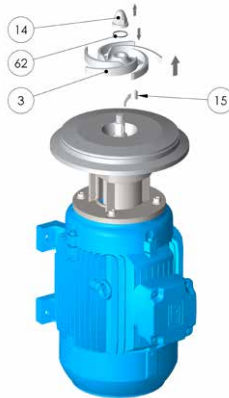

Unscrew the nut (14) anti-clockwise:
1) with a pneumatic wrench
2) with spanner
or blocking the pump shaft from motor side. Remove the impeller (3) and the key (15).



Extract the rotary part of the mechanical seal (7) and turn it anti-clockwise to extend the spring.

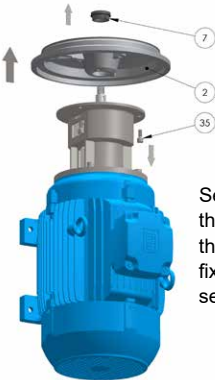

Separate the cover (2) from the lantern bracket (5) with the screws (35). Pull off the fixed part of the mechanical seal (7) from the cover.

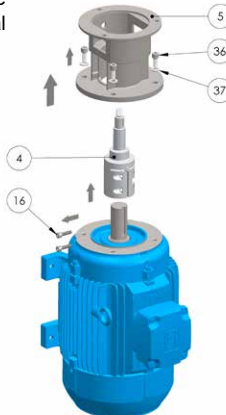

To disassemble the shaft loosen the screws (16) and screw a third screw in the central hole to enlarge the shaft (4) and make the motor extraction easier.

13 ASSEMBLY

By performing the disassembly operations in the opposite order, the pump can be assembled. Fit the shaft of the pump on the motor shaft without tightening the screws (16), then install lantern (5), cover (2), mechanical seal (7) and impeller (3).

Comply with allowance references "A" of table (Tab. 1) to assemble the impeller (3).

Block the impeller to the shaft (4) and check that allowance "A" is correctly placed to the cover (2).

The axial movement of the pump shaft (4) allows the right positioning.

Block the shaft (4) with the screws (16) to complete the operation taking care to keep the tightening torque (Tab. 2).

Reference table for assembly allowance

	"A"
CN1	0,4
CN2	0,6
CN3	0,7

Tab. 1

A = Impeller - casing assembly allowance

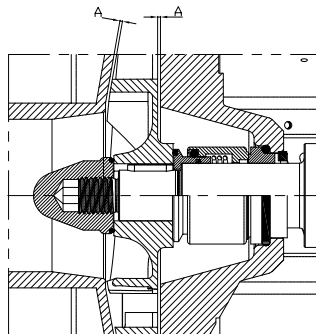

Tab. 2

Pump size	Power (kw)	Ø Shaft screw	Tightening torque (N.m.)
CN 1	1,1 - 7,5	M6	9
CN 2	1,1 - 7,5	M6	9
CN 2	11	M8	21
CN 3	5,5 - 7,5	M8	9
CN 3	11 - 15	M8	21

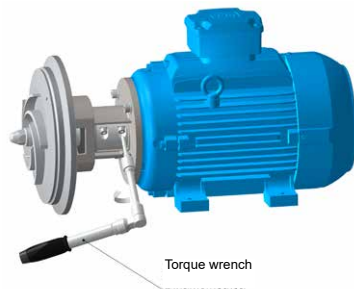

14 EXTENDED STOP

When stopping the pump for a longer time, empty the pump completely and wash it accurately in order to avoid the formation of scales and/or encrustations. When starting the pump again, please follow the above-mentioned instructions.

15 CLEANING PROCEDURE (CIP –CLEANING IN PLACE)

The cleaning of stainless steel pumps depends on the process liquid.

Typically the cleaning process should be developed by a plant responsible of sanitization.

C.S.F. Inox recommends a fluid velocity between 1,5-3 m/s, with rinsing water and chemical agent like alkaline detergent and acid.

When using the pump for liquids that tend to harden or crystallize, always make sure that it is washed before periods in which the machine is out of service. This will ensure durability of the seal and of the pump itself.

Chemicals like hypochlorite and chlorine must be avoided because stainless steel could be damaged by corrosion.

Alkaline detergent:

A sodium hydroxide/water solution may be used at concentration 1-3% at a temperature of 70-90°C; a surfactant could be added to increase the rinse cleaning.

Acid solution:

It is used to neutralize alkaline residual and for the passivation of the stainless steel surface; a solution of nitric acid at 1-2,5% could be used at ambient temperature up to 45°C.

Other acid solution could be: citric acid and water (0,5-3% at 70°C) and phosphoric acid at 0,5% with a temperature up to 45°C (with inhibitor of corrosion).

Suggested cleaning process:

- 1) Prerinse with cold water (15-25°C) for 10-15 minutes to remove any residue.
- 2) Warm prerinse with water at 45-60°C for 10 minutes.
- 3) Rinse with alkaline solution at 70-95°C for 20-30 minutes.
- 4) Intermediate rinse with water (warm or cold) up to 60°C for 5-10 minutes.
- 5) Rinse with acid solution like nitric acid for 10 – 15 minutes at ambient temperature.
- 6) Final rinse with cold water for 10-15 minutes or until any traces of cleaning agent have been removed.

Caution:

- 1) During the CIP process there are thermal expansion: take care that there are not rapid temperature variation.
- 2) Chemical agents at high temperature can cause potential health risk: respect the safety regulation and use protection devices
- 3) Control the concentrations and temperature of chemical agents during the CIP.
- 4) Store the cleaning agents in compliance with the safety regulations

Sterilization:

If requested, a sterilization can be carried out by means of hot water or steam; the pump must be stopped during the sterilization process with steam. See the admissible temperature for sterilization depending on gasket compound.

Temperature limits for rubber gasket	Steam/hot water	Chemical bactericidal
EPDM	121°C	82°C
FPM/FKM	149°C	82°C

Impeller nut cleaning and sterilization:

- 1) The dismantled nut should be cleaned before assembling (internal threads).
- 2) Clean the nut with Ultrasound washing system or detergent and rinsing with clean water.
- 3) Sterilize the nut with steam at 143°C for 30 minutes in autoclave or using chemicals solution (i.e. glutaraldehyde solution). Do not use chlorine solutions because stainless steel could be damaged by corrosion.

16 DECOMMISSIONING



Proceed as follows when dismantling the pump:

- Disconnect the electrical and fluid connections as prescribed by established standards and regulations.
- Disassemble all the pump's components and wash them for sorted disposal, and thoroughly clean the pump's frame.

The following materials are used in the principal components:

- Pump casing, cover, impeller, shaft, impeller nut: AISI 316L stainless steel (for special alloy pumps, refer to the bill of materials)
- Elastomers/polymers: NBR-EPDM-FKM-FFKM-PTFE
- Mounts and external parts: AISI 304
- Other components: composite mechanical seals, stainless steel and elastomers, ball and roller bearings
- Motor: aluminium - cast iron – copper (refer to the manufacturer's manual for details)
- Exhausted oil and grease

Refer to the pump's bill of materials (included with this manual) for further details on the materials of which the parts are composed.

There are no components containing asbestos, cadmium or lead, PBB or PBDE.

WARNING The user must scrap the pump in observance of local regulations.



C.S.F. Inox S.p.A. Strada per Bibbiano, 7 - 42027 Montecchio E. (RE) - ITALY EU

Ph +39.0522.869911 r.a. - Fx +39.0522.865454 - italia@csfit - www.csfit

Export Department • Commercial Étranger • Comercial Extranjero

Ph +39.0522.869922 - Fx +39.0522.869841 - export@csfit - www.csfit



All the instructions, data and representations (in whatever way executed) listed in this publication are indicative and do not bind. C.S.F. does not stand surety or undertake any obligation for the utilisation of this document and for the information contained. In particular, it does not guarantee against omissions or errors of the data and drawings here indicated.
Notice that the technical specifications, information and representations in this document are merely indicative and approximate. C.S.F. INOX reserves the right at any moment and without notice to modify the data, drawings and information indicated in this document.