

TECHNICAL SERVICE
+39 0522 869832

SELF-PRIMING PUMPS
TESTED AND APPROVED ACCORDING
TO THE



SANITARY STANDARDS

ASH Series

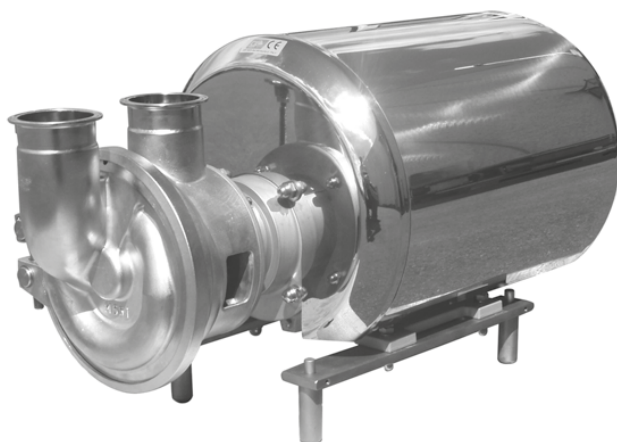

INSTRUCTIONS FOR INSTALLATION,
OPERATION AND MAINTENANCE

CSF
inox

INDEX

	FOREWORD
1	SYMBOLS
2	SAFETY WARNINGS
3	GUARANTEE
4	GOODS TRANSPORTATION, RECEIVING AND TRANSFERRING
	4.1 Transportation
	4.2 Receiving
	4.3 Transferring
5	DESCRIPTION
6	SOUND EMISSION
	6.1 Noise level
7	NON-PERMITTED USES
8	INSTALLATION
	8.1 Suction and inflow conditions
	8.2 Piping
	8.3 Electrical connection
9	OPERATION
	9.1 Preliminary operations and starting
	9.2 Operating checks
	9.3 Extended stop
	9.4 Cleaning the pump
10	SPARE PARTS
11	SEALS
12	MAINTENANCE
	See enclosure (DOCA NO 3241)
13	WORKING IRREGULARITIES
14	DECOMMISSIONING
15	DISASSEMBLING THE ASH PUMP

FOREWORD

- Read the instructions carefully and keep them for future consultation.
- C.S.F. Inox S.p.A. reserves the right to make any changes to the documentation it deems necessary without being obliged to update publications that have already been issued.
- When requesting information, spare parts or assistance, always specify the pump type (*) and serial number (**) in order to ensure fast and efficient service: the complete code is given on the plate and in the purchase documents.





		POMPE – RACCORDERIA Montecchio E. – ITALY 0522-869911 / www.csf.it			
				n° 02 - 11 739	
○		Item.		○	
Modello		ASH 65-4-7,5/B.PTH1 (*)			
N° Matr.	A027120 (**)	Anno	2007	Giri max.	1430
kW	7,5	Volt	400-690	Hz	50

Plate example

1 SYMBOLS

	WARNING	<i>Pay great attention to the text parts indicated by this symbol.</i>
		Danger: <i>the non-observance of instructions can cause serious damages to persons and/or objects.</i>
		Danger: <i>only skilled personnel is allowed to carry out operations concerning the electric parts.</i>

2 SAFETY WARNINGS

When the pump is working the following occurs:

- Electric parts are in tension.
- Mechanical parts are moving.
- Pump body, pipelines and articulations are under internal pressure. Therefore do not remove any protection or locking, do not loosen screws or clampings, as this can cause serious damages to persons or objects. The clamp joining the pump casing and the cover must be well tightened and it should not be easily unscrewed by hand. The tightening of the clamp must be carried out by means of a key and NOT by hand.
- Non-observance of inspection and maintenance can cause damages to persons and objects, especially when dangerous or toxic liquids are pumped.
- When pumping liquids at a temperature over 60° C, adequate protection and warning signals are required.
- When you buy a pump with bare shaft, motor coupling operations have to be carried out according to technical directions and law, providing adequate protections for joints, gear belts, etc.
- Operations on the electric parts have to be carried out by skilled personnel, according to technical directions and law, on authorisation of the responsible installer.
- Installation must ensure an adequate ventilation, in order to cool the engine, as well as enough space for maintenance operations.

Before carrying out any operation which requires to disassemble the pump (inspection, cleaning, seal replacement, etc.), the following preliminary operations have to be carried out:

- switch off engine tension and disinsert electric connection;
- close valves on suction and outlet pipelines, in order to avoid the risk of inundation;

- use adequate protections for hands and face, if the pump contains liquids which are injurious to health (for example acids, solvents, etc.);
- consider if the liquid which flows out of the pump when disassembling is dangerous and arrange for adequate safety measures.

3 **GUARANTEE**

All products manufactured by C.S.F. Inox are guaranteed to the purchaser, for one year from the date of purchase, against hidden defects in materials or manufacture, providing that they are installed and used according to instructions and recommendations of the manufacturer. Excluded from the guarantee other than distinctive wear and tear are repairs to damage caused by improper use, abrasion, corrosion, negligence, defect of installation, non-observance of inspection and maintenance, use of non-genuine spare parts, cause of accident or fortuity and from any action carried out by the purchaser not according to the normal instructions of the manufacturer.

WARNING Before returning to C.S.F. Inox S.p.A. any item to be substituted or repaired under guarantee, inform about the problem the Customer Assistance Office and follow instructions of the manufacturer. Any item must be properly packed in order to avoid damages during the transferring and **a technical report explaining the fault occurred, must accompany the returned item/s.**

Any item with a presumed fault should be returned to C.S.F. Inox S.p.A. with shipment costs at purchaser's charge, unless different agreements are given.

C.S.F. Inox S.p.A. will examine, repair and/or replace the returned piece and then send it back to the purchaser on ex-works basis. Should the piece be found under warranty, no further costs will be debit the purchaser. If, on the contrary, the fault is not found under warranty, all necessary reparations and replacements will be charged at normal cost to the purchaser. Commercial parts incorporated in C.S.F. products are guaranteed by their corresponding manufacturers.

4 **GOODS TRANSPORTATION, RECEIVING AND TRANSFERRING**

4.1 **TRANSPORTATION**

The packings of all pumps manufactured by C.S.F. Inox - S.p.A. are defined when making the order. Unless prior arrangements are given, goods will be packed only for transit conditions and not for long-term storage; in case it should be necessary to store the pumps outside, you are requested to cover the pumps appropriately in order to protect the electrical parts (motor) from rain, dust, humidity etc.

4.2 **RECEIVING**

WARNING By goods receiving, the wholeness of packing must be verified, in order to identify possible damages to the content occurred during transferring and to claim them immediately to the carrier. Should any damage be ascertained, the following procedure must be observed:

- collect the goods with reservation;
- take the necessary pictures showing the damages;
- notify the suffered damages, by registered airmail, to the carrier by sending at the same time the pictures taken to show the damaged pieces.

4.3 **TRANSFERRING**

Carry the packed pumps as close as possible to the place of installation by means of appropriate lifting devices and unpack them. During this operation take care, as unsteady parts could fall down.



The material used for packing (wood, paper, cellophane, etc.) should be properly got rid, according to the corresponding rules in force in receiver's country.

After unpacking the pump, use special lifting belts and move the pump-motor-set to the place of installation; never use the eyebolts on the motor to move the pump, as the eyebolts are for moving the motor only. In versions complete with shroud, take the shroud off before moving the pump-motor-set, in order to avoid damages.

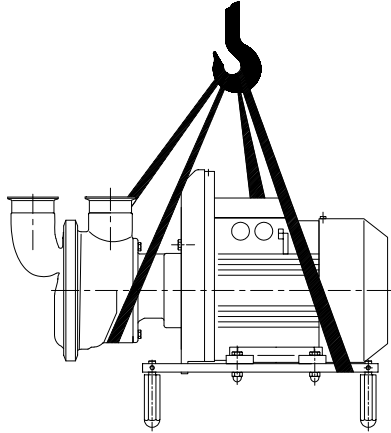

5 DESCRIPTION

The pumps of serie ASH, manufactured according to the 3A Sanitary Standards, are centrifugal side channel self-priming with star-shaped impeller; both the ports are located on the vertical axe. All models have clamp connections according to ISO 2852 standard (unless otherwise requested). The pump front cover is easy to open to improve cleaning and inspection operations; all models are fitted with mechanical seals and the materials used for the components of mechanical seal are chosen according to the liquid to be pumped.

Designed in close-coupled version, fitted with independent standard electric motors B3B14 shape, IP 55 protection (unless otherwise requested).

All product wetted surfaces are polished with Ra max. 0,8 micron.

These pumps are designed for applications where the liquid to be pumped :

- is not subject to pollution of any kind,
- is at a temperature between -20°C and +100°C,
- must under no circumstances come into contact with the outside environment,
- is chemically aggressive.

6 SOUND EMISSION

6.1 Noise level

The sound pressure level of self-priming pumps is the following (see table):

		Pump type	
Sound pressure level dB(A)	< 80	ASH 40 - 50 Hz	
	< 80	ASH 50 - 50 Hz	
	81+85	ASH 50 - 60 Hz	
	86+90	ASH 60 - 50 Hz	ASH 65 - 50 Hz

The measurement has been made by means of a phon-meter placed at 1 m distance from the pump and at a height of 1.6 m from the ground.

Preliminary condition is that the pump is fixed correctly; the above mentioned values do not take into account external noise sources (e.g. valves, abrupt hydraulic deflections).

7 NON-PERMITTED USES

Do not use the pump with a suction pressure greater than the specified value (0.5 times the discharge head generated by the pump).

The pump must always be used in an environment appropriate to the level of protection of the motor. Always check this on the motor plate before installation.

WARNING THE PUMP MAY NOT BE USED IN ENVIRONMENTS WHICH REQUIRE A HIGHER LEVEL OF PROTECTION OR A HIGHER SPECIFICATION MOTOR OR ELECTRICAL PARTS.

Components complying with the safety standards for the environment in question must be used.

8 INSTALLATION

8.1 SUCTION AND INFLOW CONDITIONS

(NPSH = Net Positive Suction Head)

NPSH of system (available NPSH)

In order to ensure that pump operation is free from cavitation, it is essential to observe the maximum permitted suction lift **ha geo max** or the minimum allowable head **hc geo min**.

NPSH of pump (required NPSH)

The centrifugal pumps can operate correctly only if vapour has not formed inside. For this reason the static head at the reference point for the NPSH is the centre of the impeller, that is the point of intersection of the pump shaft axis with the vertical plane that passes through the external points of the blade inlet corners.

NPSH_{rec.} is the value required by the pump, expressed in metres, obtained from the performance curve. In practice 0.5 m should be added to this value as a safety margin.

8.2 PIPING

In order to prevent the creation of harmful stresses, the suction and discharge pipes must be connected to the pump ports without the use of force. These pipes must also be supported independently avoiding causing stresses on the pump. The internal diameter must be the same size as the pump connections. It must in any case not be smaller to avoid head loss and/or poor performances. Always use elbows with large radius. If the pipe diameter changes along the line, use reduction cones, choosing the ones that are most suitable for avoiding the formation of air pockets (Pict. 1).

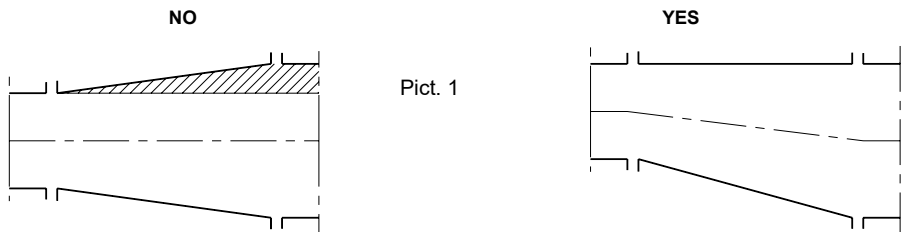

The suction pipe must be as short as possible and rise as it moves towards the pump if it is sucking from a tank, if on the other hand the pump is below the level of the liquid, the pipe should descend slightly. If the pump is used for transporting hot liquids, fit expansion joints to compensate any expansion of the piping. The maximum velocity of the liquid in the suction pipe must not be greater than 3 m/s. Velocities between 1 and 2 m/s are recommended.

The suction pipe must be designed in such a way as to prevent air from entering the pump. For this reason, when sucking from a tank located at a lower level, the pipe must reach below the free surface of the liquid. Avoid creating obstacles which could increase suction losses disrupting smooth fluid flow. Make sure that there are no restrictions, sharp turns or tight elbows on the discharge line, since these increase disturbance near the pump.

8.3 ELECTRICAL CONNECTION



Make the electrical connection only after the hydraulic connection has been completed; set up the motor control system in conformity with the technical standards and regulations in force (EN 60204-1): in

particular a manual electric power switch must be installed with adequate current switching capacity; devices for overcurrent and overload protection (e.g. fuses, automatic switches, etc.) must also be fitted, plus, if necessary, a device to prevent accidental restarting.

Check that the main frequency and voltage and the available power are suitable for the motor installed. All the material used for the electrical connection (cables, cable clamps, switches and shielding) must have a suitable level of protection for the environment in which it is installed. Be sure to use cables of sufficient cross-section for the current shown on the motor plate so as to prevent them from overheating. Before doing anything else, make the motor's earth connection, using the terminal on the motor and a cable of sufficient cross-section. The cables may be connected to the terminal board using either a delta or star arrangement. Follow the data given on the motor plate for the main voltage, as shown in the diagram in pict.2; ensure that the terminals are clean and tight and not under stress.

When starting, the motor's current absorption increases briefly to 5-6 times the nominal value. If the mains supply is unable to sustain this increase in absorption, use a star-delta starter or other kind of device (e.g. an autotransformer).

C.S.F. Inox S.p.A. will accept no responsibility for damage to property and/or injury to persons caused by failure to comply with technical standards and regulations in force.

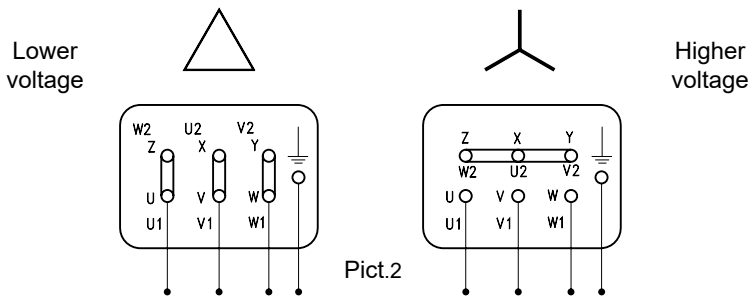

9 OPERATION

9.1 PRELIMINARY OPERATIONS AND STARTING



When first starting, fill the pump with liquid so as to create the pressure drop required for suction. When starting subsequently the quantity of liquid that remains in the pump will be sufficient to ensure self-priming even if the pipe is empty. Make sure that the pump does not become completely empty in the event of installation under a vacuum or to a siphon. If necessary, fit a check valve.

- Check that the pump turns freely under hand pressure.
- Check that the clamp joining the pump casing and the cover is well tightened and that it cannot be easily unscrewed by hand. The tightening of the clamp must be carried out by means of a key and NOT by hand.
- Check that the pump turns in the market direction.
- Check that any gate valves installed on the suction and discharge pipelines are open.
- Start the pump and check the turns direction; before restarting it is extremely important to wait until the pump has stopped moving completely.

9.2 OPERATING CHECKS

- If the pump does not generate the required discharge head rapidly, facilitate priming by stopping the pump and adding liquid.
- Check that the absorption of the motor does not exceed the value specified on the plate.
- The pump must always work smoothly and without vibrations.
- Do not operate without liquid and in any case avoid prolonged operation with the discharge gate valve closed.

WARNING WITH SERIES ASH PUMPS NEVER CLOSE DISCHARGE SIDE COMPLETELY.

- Mechanical seal: check that there is no leakage along the shaft.

9.3 EXTENDED STOP

When stopping the pump for a longer time, empty the pump completely and wash it accurately in order to avoid the formation of scales and/or encrustations. When starting the pump again, please follow the above mentioned instructions.

9.4 CLEANING THE PUMP

The pump does not require any special washing procedures. The washing cycles normally used for the plant in which it is installed are quite satisfactory. When using the pump for liquids that tend to harden or crystallize, always make sure it is washed before periods when the machine is to be taken out of operation. This will ensure durability of the seal and of the pump itself.

It is the user's responsibility to ensure that the washing liquids are compatible with the process liquid and the pump.

10 SPARE PARTS

RECOMMENDED SPARE PART FOR TWO YEARS OF OPERATION ACCORDING TO THE NUMBER OF PUMPS INSTALLED - VDMA STANDARD					
Denomination	Number of pumps (including reserve)				
	1	2	3	4	5
MECHANICAL SEAL "EHC", according to 3A standards	1	2	3	4	4
PUMP BEARING	1	1	1	2	2
CASING PUMP O-RING SEAL, according to 3A standards	2	3	5	6	7
IMPELLER NUT O-RING SEAL, according to 3A standards	2	3	5	6	7

C.S.F. Inox declines all responsibility for damage or injury resulting from the use of non-original spare parts

11 SEALS

All the C.S.F. self-priming pumps of the ASH series are fitted with a single internal protected and balanced seal, with diameter of 28 mm and unified seats according to EN 12756 - ISO 3069 standards. The materials of the mechanical seal components are chosen according to the liquid to be pumped.

WARNING Before using the pump for any liquids other than those specified when selecting and ordering, ensure that mechanical seals and gaskets are suitable for the new product.

12 MAINTENANCE

SEE ENCLOSURE FOR MAINTENANCE INSTRUCTIONS OF SEAL AND PUMP.(DOCA NO.3241)

13 WORKING IRREGULARITIES

The pump does not prime

- Air has entered the suction piping; check the seals on the fittings and tighten them sufficiently.
- Suction pipe not submerged in liquid.
- Clearances between impeller/cover and impeller/body have increased. Check and correct.
- No liquid in the pump. Introduce liquid.
- Reduce loss of suction head; reduce the suction height.
- Formation of air pockets; eliminate and if necessary fit an air unloader on discharge.

No flow

- Pump not primed; (see point 8 and previous point).
- Pump turning in wrong direction.
- Suction port obstructed.
- On-off valves closed.

Insufficient flow

- Increased system back pressure on discharge side; increase piping diameter.
- Air entering mechanical seal; check its condition.
- Viscosity of fluid greater than that specified in the order. Contact manufacturer.
- Clearances between impeller/cover and impeller/body have increased. Check and correct.

Loss of head

- Back pressure on discharge side has fallen; throttle the suction pipe.
- Clearances between impeller/cover and impeller/body have increased. Check and correct.

Increase in absorbed power

- Flow rate is lower than required.
- Pump is turning at higher speed.
- The impeller does not turn freely. Check it.
- Viscosity and/or specific weight are higher than stated.
- Bearings are not in good condition.

Increase in absorbed current

- The power required has increased (see previous point).
- Main voltage value has fallen.
- There is a fault in the electrical system.

14 DECOMMISSIONING



Proceed as follows when dismantling the pump:

- Disconnect the electrical and fluid connections as prescribed by established standards and regulations.
- Disassemble all the pump's components and wash them for sorted disposal, and thoroughly clean the pump's frame.

The following materials are used in the principal components:

- Pump casing, cover, impeller, shaft, impeller nut: AISI 316L stainless steel (for special alloy pumps, refer to the bill of materials)
- Elastomers/polymers: NBR-EPDM-FKM-FFKM-PTFE
- Mounts and external parts: AISI 304
- Other components: composite mechanical seals, stainless steel and elastomers, ball and roller bearings
- Motor: aluminium - cast iron – copper (refer to the manufacturer's manual for details)
- Exhausted oil and grease

Refer to the pump's bill of materials (included with this manual) for further details on the materials of which the parts are composed.

There are no components containing asbestos, cadmium or lead, PBB or PBDE.

WARNING The user must scrap the pump in observance of local regulations.

15 DISASSEMBLING THE ASH PUMP STEP 1

Loosen the knob, open and remove the clamp (9); remove the cover (2) and take the O-Ring seal (13) off the casing (1). Unscrew the impeller nut (10) with the O-Ring seal (16), slide the impeller out (3) and take the key (11) off the seat of the shaft (4). Remove the mechanical seal (6). Take the rotating part of the shaft off (4) and also the shim rings (19) that create assembly clearance.

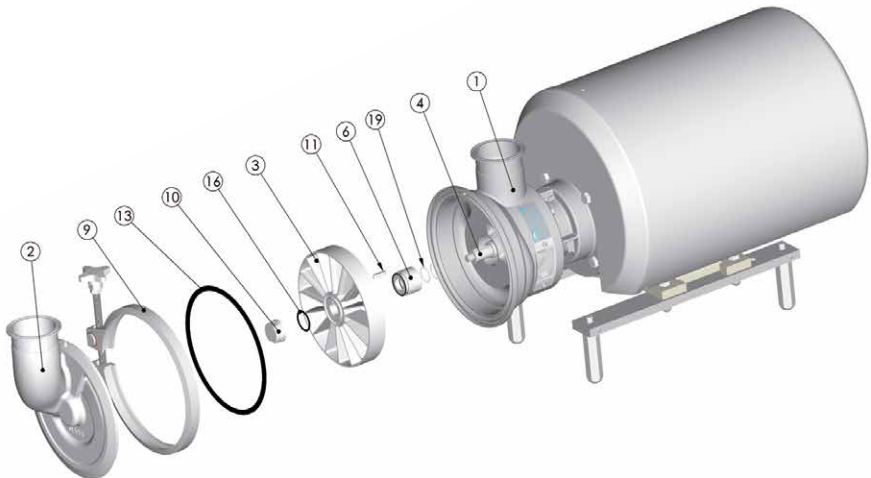



C.S.F. Inox S.p.A. Strada per Bibbiano, 7 - 42027 Montecchio E. (RE) - ITALY EU
Ph +39.0522.869911 r.a. - Fx +39.0522.865454 - italia@csf.it - www.csf.it

Export Department • Commercial Étranger • Comercial Extranjero
Ph +39.0522.869922 - Fx +39.0522.869841 - export@csf.it - www.csf.it



All the instructions, data and representations (in whatever way executed) listed in this publication are indicative and do not bind. C.S.F. does not stand surety or undertake any obligation for the utilisation of this document and for the information contained. In particular, it does not guarantee against omissions or errors of the data and drawings here indicated.
Notice that the technical specifications, information and representations in this document are merely indicative and approximate. C.S.F. INOX reserves the right at any moment and without notice to modify the data, drawings and information indicated in this document.